

Customer	Project	Page	1 / 1
Customer no.	Project no.	Date	16/11/2012
Contact	Position	SERIES A, AX	
Care of	Location		

A 15-1 11 5720.0150
 Variable speed Mini Energy Pump

Requested data

Flow	0 m³/h
Head	0 m
Fluid	Water, pure
Temperature	20 °C
Working pressure	1000 kPa

Operating data

Flow	
Head	
Speed stages	
Power input P1	
Permitted working pressure	1000 kPa
Min. fluid temperature	15 °C
Max. fluid temperature	95 °C

Required working pressure
 Values are valid for hot water,
 Altitude 500m above sea level.
 Changing of required working pressure at +/- 0.01bar
 per +/- 100m altitude above sea level.

75 °C	95 °C
10 kPa	55 kPa

Pump data

Installation dimension	1½" x 180
Rated voltage	1~230 V 50
Rated current	0.8 A
Rated power P2	0.107 kW
Insulation class	F
Degree of protection	IP 44

**Short-circuit-proof motor doesn't
 required overload protection.**

Materials

Pump casing	Cast iron
Impeller	Plastic
Can	Chrome-Nickel Steel
O- Ringe	EPDM 75
slide bearing	Ceramic
Shaft	Ceramic

Weight 3.8 kg

51-54: Error message
 (potential- free closing
 contact closed if there
 is a malf unction)
 contact load max.250V~,1A

51-52:
 (Zero potential normally- closed contact,
 open with fault)
 Contact load max.250V~,1A

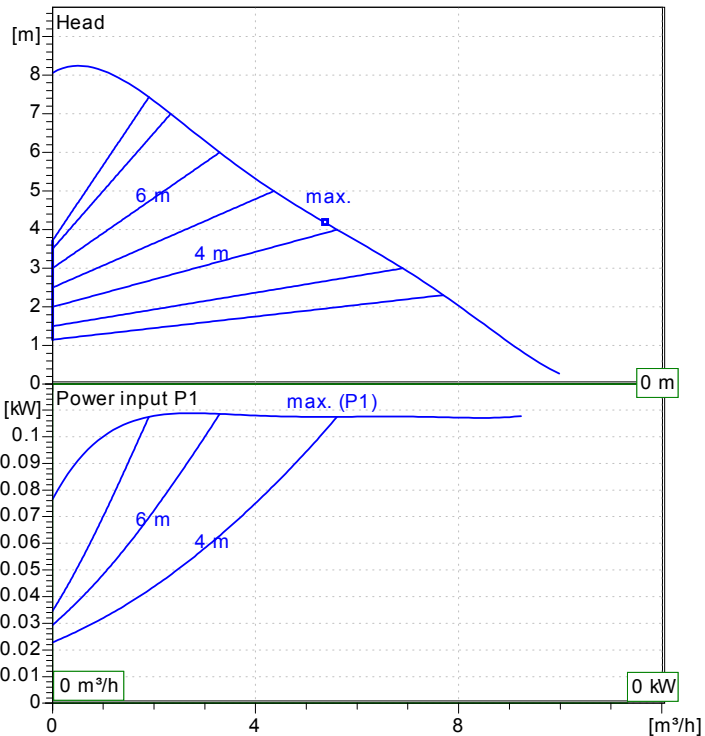
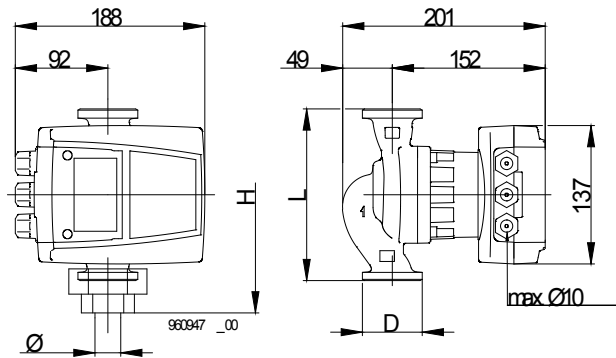

Electrical connection

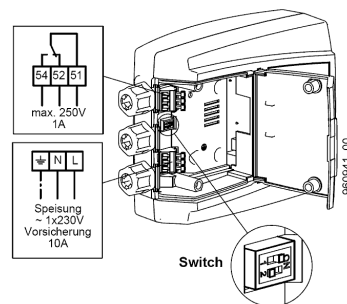

Remarks: